

**Early 69
350**

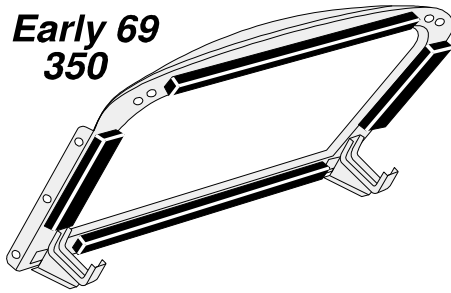

O Early 69 350 Radiator Seal 4 Pc Kit
Includes upper & lower horizontal seals, plus LH & RH vertical seals with PSA. ? Early 69 mode b do not have holes in the radiator support for PIF. Therefore, PIF are not used with these early seals. 1274306 20.00

How to Tell Early from Late 69 350
Early 350 does not have any holes or use PIF. Late 350 has mounting holes and does use PIF

**Late 69-72
350**

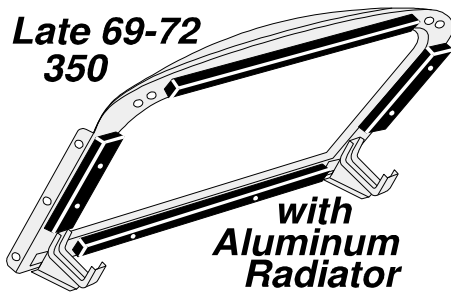

P Late 69-72 350 Radiator Seal 4 Piece Kit with Aluminum Radiator
Includes upper & lower horizontal seals plus LH & RH vertical seals with PSA & pre-punched mounting holes. ? Late 69 mode b have pre-punched holes in radiator support for the PIF. Uses 6 PIF. 1274323 20.00

**Late 69-72
350**

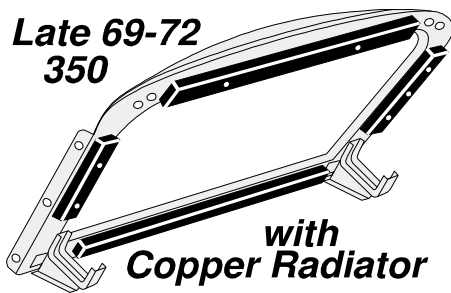

Q Late 69-72 350 Radiator Seal 4 Piece Kit with Copper Radiator
Includes upper & lower horizontal seals plus LH & RH vertical seals with PSA & pre-punched mounting holes. ? Late 69 mode b have pre-punched holes in radiator support for the PIF. Uses 7 PIF. 1274307 20.00

**Early 69
427**

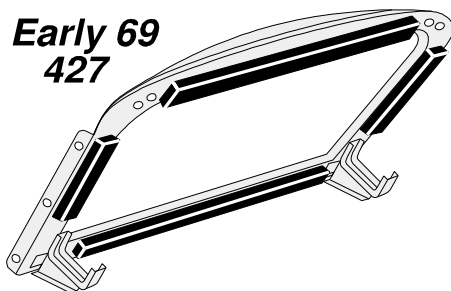

R Early 69 427 Radiator Seal 4 Piece Kit
Includes upper & lower horizontal seals plus LH & RH vertical seals with PSA. ? Early 69 mode b do not have holes in the radiator support for PIF. PIF are not used with these mode b. 1274309 20.00

How to Tell Early from Late 69 427
Early 427 does not have mount holes or use PIF. Late 427 has mounting holes and does use PIF

**Late 69-72
427-454**

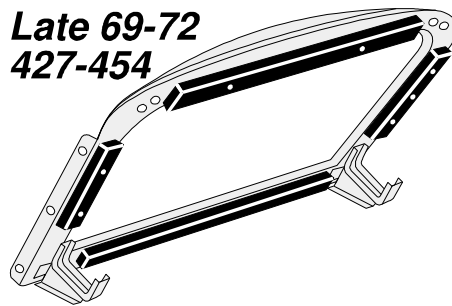

S Late 69-72 427 Radiator Seal 4 Piece Kit
Includes upper & lower horizontal seals plus LH & RH vertical seals with PSA & pre-punched mounting holes. ? Late 69 mode b have pre-punched holes in radiator support for the PIF. Uses 7 PIF. 1274311 20.00

T 69-72 Heavy Duty Radiator Support Seal 4 Piece Kit

Includes upper & lower horizontal seal, plus LH & RH vertical seals with PSA. Use with L-88, LR-1 or LR-2. PIF are not used. 1274440 20.00

U 70-72 LT-1 Radiator Seal 4 Piece Kit

Includes upper & lower horizontal seals, plus LH & RH vertical seals with pre-punched mounting holes & PSA. LT-1 Except R-1. Uses 5 PIF. 1274314 20.00

73-75 Radiator Seal Kits

Most 69-78 seals use PIF = Push In Fasteners. Fasteners are not included with Seal Kits.

	4 Piece Seal Kit	PIF required	
V	73 350 or 454 Kit	7	1274445 20.00
W	74-75 except AC Kit	7	1274446 20.00
X	74-75 with AC Kit	7	1274447 20.00

**73 350
and 454**

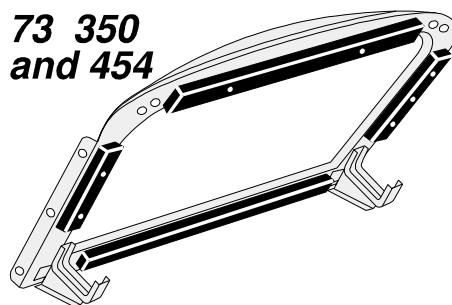

V 73 350 or 454 Radiator Seal 4 Piece Kit
Includes upper & lower horizontal seals, plus LH & RH vertical seals with pre-punched mounting holes & PSA. Uses 7 PIF. 1274445 20.00

**74-75
except
AC**

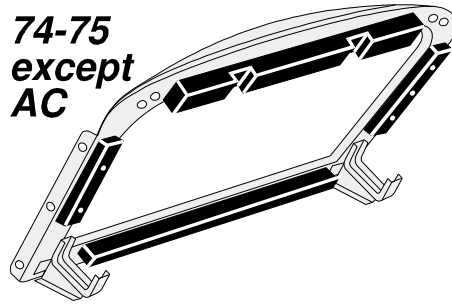

W 74-75 350 or 454 except AC Radiator Support Seal 4 Piece Kit
Includes a tick notch ed upper horizontal seal, lower horizontal seal, plus LH & RH vertical seals with pre-punched holes & PSA. Uses 7 PIF. 1274446 20.00

**74-75
with AC**

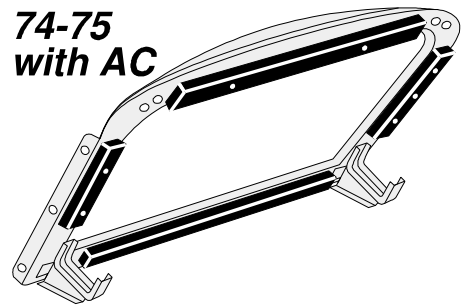

X 74-75 350 or 454 with AC Radiator Support Seal 4 Piece Kit
Includes upper & lower horizontal seals, plus LH & RH vertical seals with pre-punched mounting holes & PSA. Uses 7 PIF. 1274447 20.00

BLEM PRODUCTS RESEARCH and DEVELOPMENT?

Blem Products boldly claims that they did "Years Of Research Developing Radiator Seals". Let's examine the bologna in this statement. Until we stopped selling to them - their entire "research" consisted of removing our labels and reselling our product.

We collect samples, blueprints and examined and compared real Corvettes over a 15 year period to assemble the information, tools and equipment necessary to produce 50 different air dam, radiator and fan shroud seal kits.

In addition Mr. Ken May, the retired Director of Warehousing and Distribution at GM gave me every blue print for these GM parts.

In the nine months from October 1994 to June 1995, Blem Products was able to duplicate our 15 year effort and they had no GM blueprints as I never shared them. They must geniuses and are wasting their talents on radiator seals. These brilliant minds should focus their efforts on the electric car or fusion. We would really benefit.

Knowing that many brilliant researchers blindly copy a repro, we often supplied them with bogus repro's to copy. They never learned the RULE: You Don't Make A Repro From A Repro - because you don't know whether the repro is really authentic or is a bogus part.

Some suppliers have even lowered prices on these bogus repro's. We sincerely feel this is a fair and equitable method of marketing blem's. Corvette consumers should not be expected to pay full price for bogus blem repro's.

Some are so anxious to dump them, they even offer them for free. You can presume that what their value is if they are free. "Buy a radiator or shroud and get a free seal kit." Why don't they just come out with the truth and say "Someone please take this crap off our hand - it's free !

Blem Products would not recognize research "If they Stepped in it, Got it on their Shoe, and it Stunk like you know what" and you can quote me on that.